

VICOR CONFIDENTIAL
 THIS DOCUMENT AND THE DATA DISCLOSED HEREIN OR
 HEREWITH IS NOT TO BE REPRODUCED, COPIED, OR
 DISCLOSED IN WHOLE OR IN PART TO ANYONE WITHOUT
 THE PERMISSION OF VICOR CORP.

| REV. | DESCRIPTION | INTL | DATE | APVD |
|------|----------------------|------|----------|------|
| 1 | RELEASED PER E140206 | GCK | 02/18/14 | SE |
| 2 | REVISED PER E141414 | SJW | 12/19/14 | REJH |
| 3 | REVISED PER E161035B | AP | 10/26/16 | BH |
| 4 | REVISED PER E170413 | GCK | 04/25/17 | REJH |

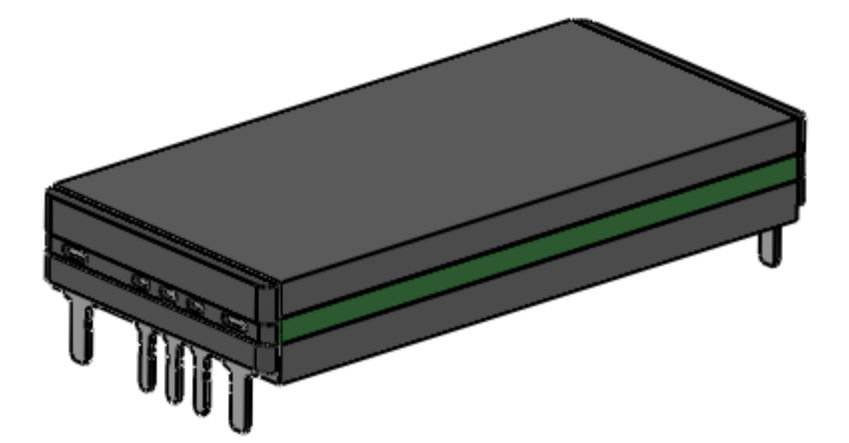
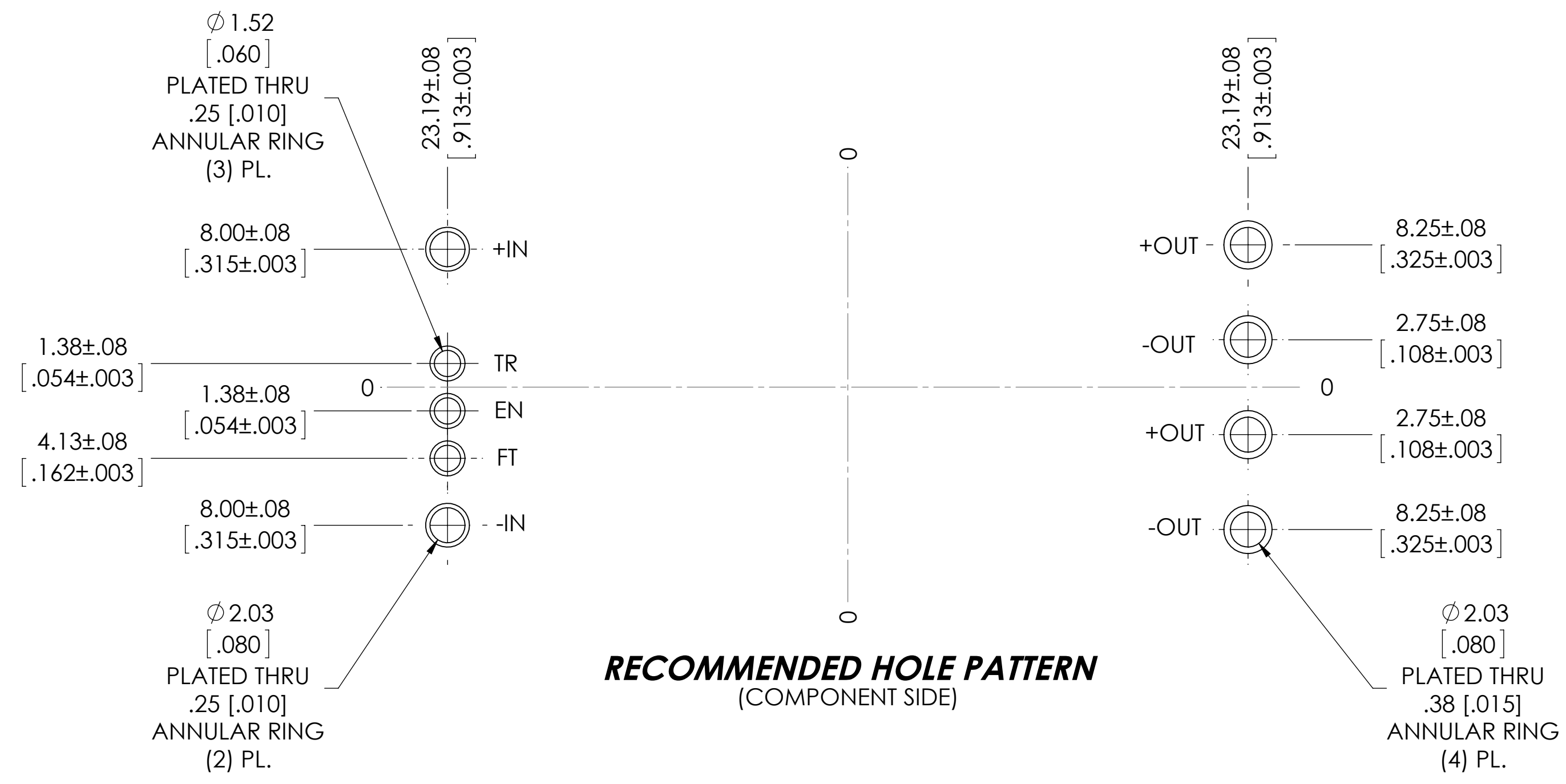
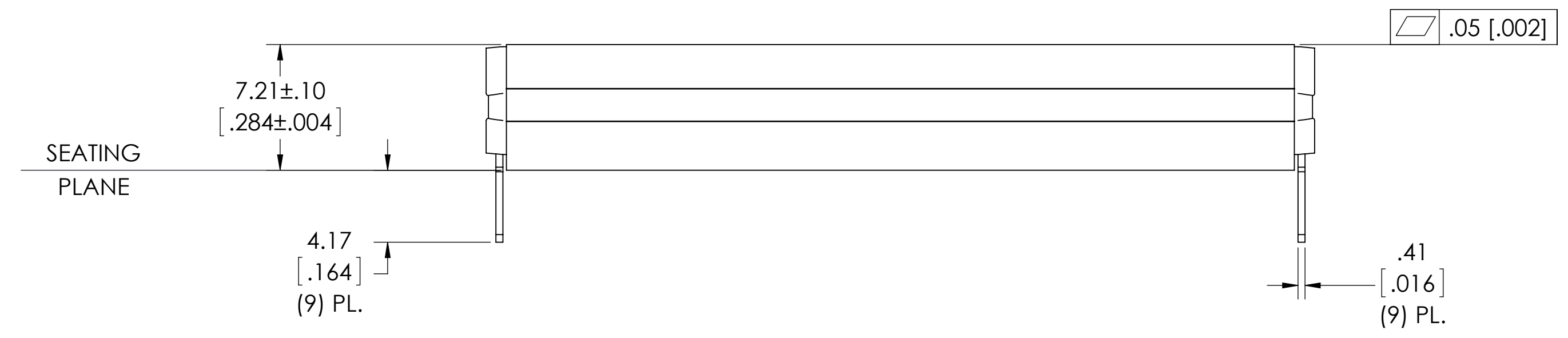
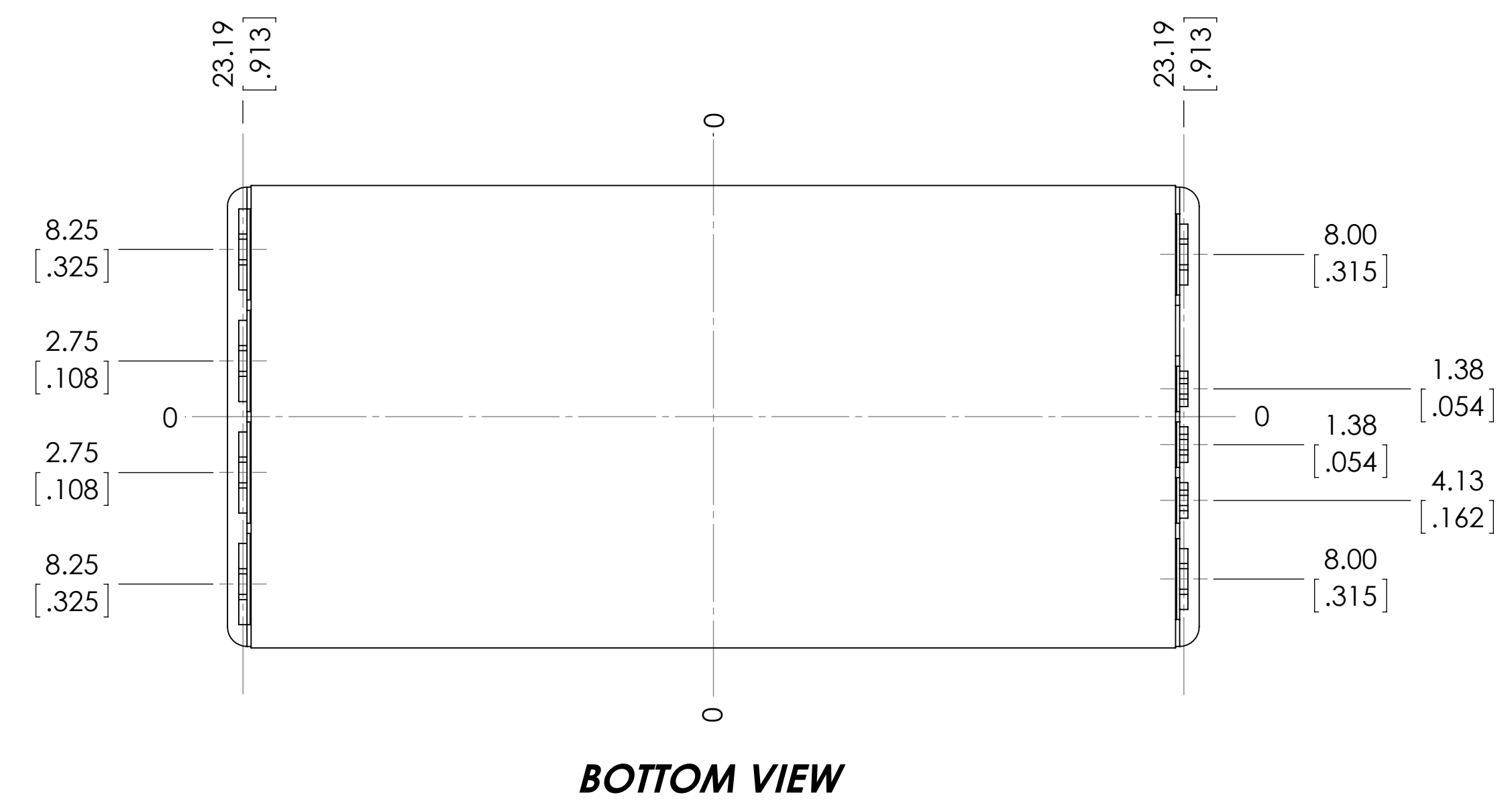
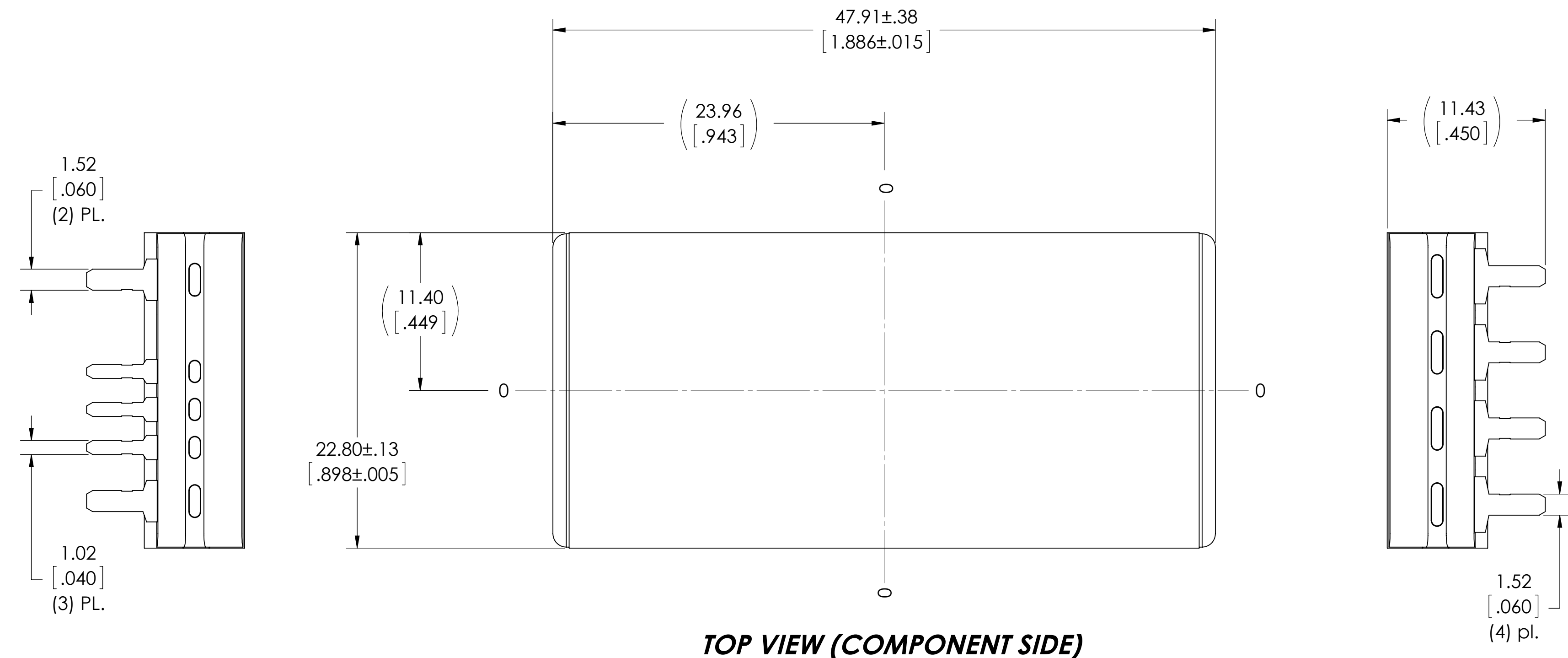

NOTES:
 1- RoHS COMPLIANT PER CST-0001 LATEST REVISION.

| | | | |
|--|------------------|---------------------------------------|---------------------------|
| DRAWN BY R.E.J. Hickey | DATE 9/9/2013 | VICOR <small>swd</small> | |
| UNLESS OTHERWISE SPECIFIED DIMENSIONS ARE: MM / (INCH) | | PRODUCT OUTLINE 4623 THRU HOLE | |
| TOLERANCES ARE: DECIMALS: ANGLES: XX (XX) = +0.25 (0.01) ±1° XXX (XXX) = +0.127 (0.005) | | SIZE D | CAGE CODE 67131 |
| THIRD ANGLE PROJECTION DO NOT SCALE DRAWING | | DWG NO 40257 | REV 4 |
| SCALE 4:1 | | SHEET 1 OF 1 | |